

**PRODUCT SPECIFICATIONS**

Elkay 3-1/2" Drain with Removable 13" (11-1/2" assembled)  
Standpipe 13" Rubber Stopper. Overall dimensions are 4-5/8" x 4-  
5/8" x 18-7/16". Made of Stainless Steel.

<b>Material:</b>	Stainless Steel
<b>Finish:</b>	Polished Stainless Steel
<b>Dimensions:</b>	4-5/8" x 4-5/8" x 18-7/16"
<b>Shipping Weight:</b>	2 lbs.

**Special Note:** Type 304 Stainless Steel body and tailpiece

- 1-1/2" O.D. x 4" tailpiece.



**AMERICAN PRIDE. A LIFETIME TRADITION.**  
Like your family, the Elkay family has values and traditions that endure. For almost a century, Elkay has been a family-owned and operated company, providing thousands of jobs that support our families and communities.

**Product Compliance:** ASME A112.18.2/CSA B125.2

[Clean and Care Manual \(PDF\)](#)

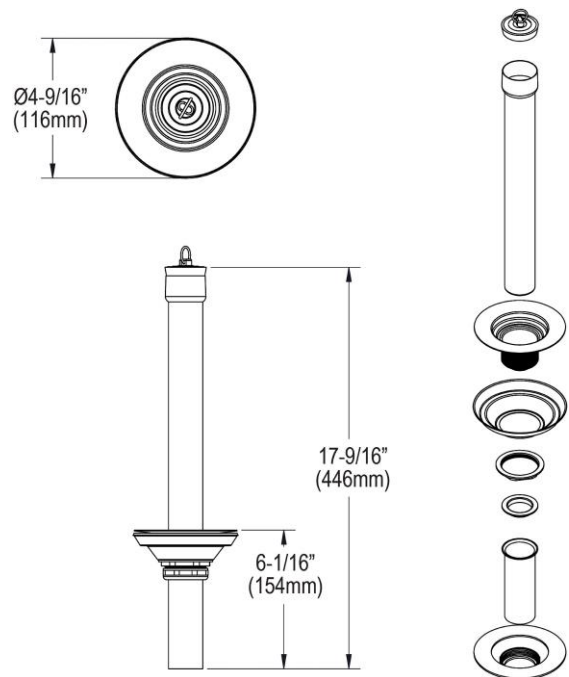

PART: \_\_\_\_\_ QTY: \_\_\_\_\_

PROJECT: \_\_\_\_\_

CONTACT: \_\_\_\_\_

DATE: \_\_\_\_\_

NOTES: \_\_\_\_\_

APPROVAL: \_\_\_\_\_

*In keeping with our policy of continuing product improvement, Elkay reserves the right to change product specifications without notice. Please visit [elkay.com](http://elkay.com) for the most current version of Elkay product specification sheets. This specification describes an Elkay product with design, quality, and functional benefits to the user. When making a comparison of other producers' offerings, be certain these features are not overlooked.*